

# — TECHNICAL SHEET

PIPE HANDLING PRODUCT SUITABLE FOR PLUMBERS, ELECTRICIANS AND SPRINKLER COMPANIES.

We offer a standard cart but it is possible, upon request, to adapt it to your needs. They are designed with quality materials, allowing a long life span.

If needed, they can be painted in different colors. Groupe RoyalTech has implemented appropriate quality control procedures to ensure that the final product complies with our established standards.

## MATERIALS

- Fork Support : H.S.S Rectangle 6" x 4 " x .188 (12 pounds / linear foot)
- Front wheels: 8" x 2" black phenolic, rotating, capacity: 1250lbs each
- Rear wheels: 8" x 2" black phenolic, fixed, capacity: 1250lbs each
- Carriage steel structure : H.S.S 1½" 1½" x 0.125 (2.21 Pounds / linear foot)

## OPTIONS AVAILABLE :

- with or without wire mesh
- With or without fork

**Price upon request, due to fluctuating steel prices**  
**\*\*Volume pricing available**

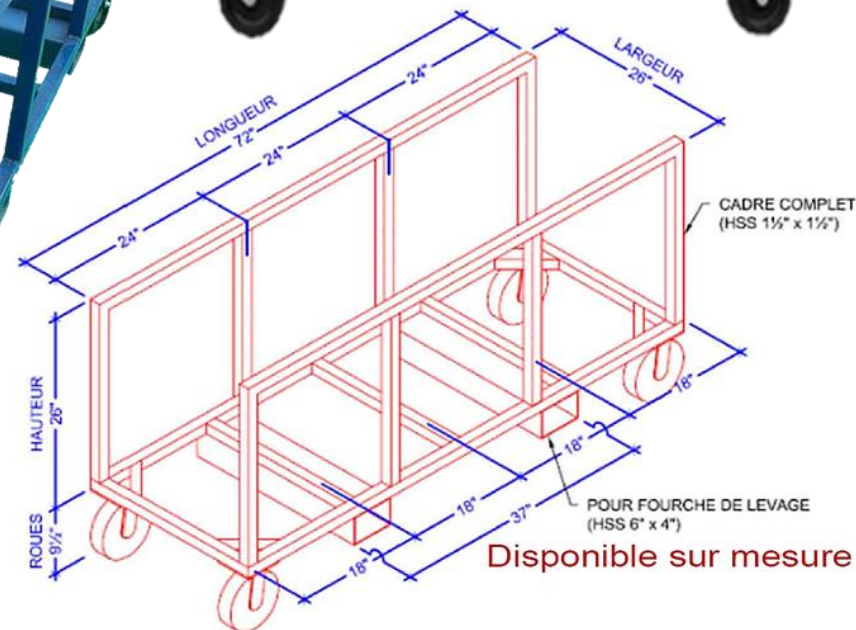
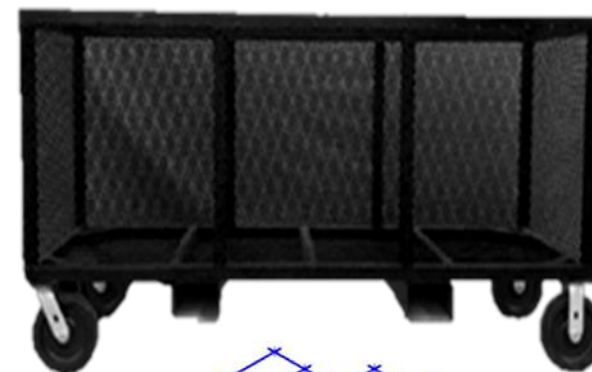
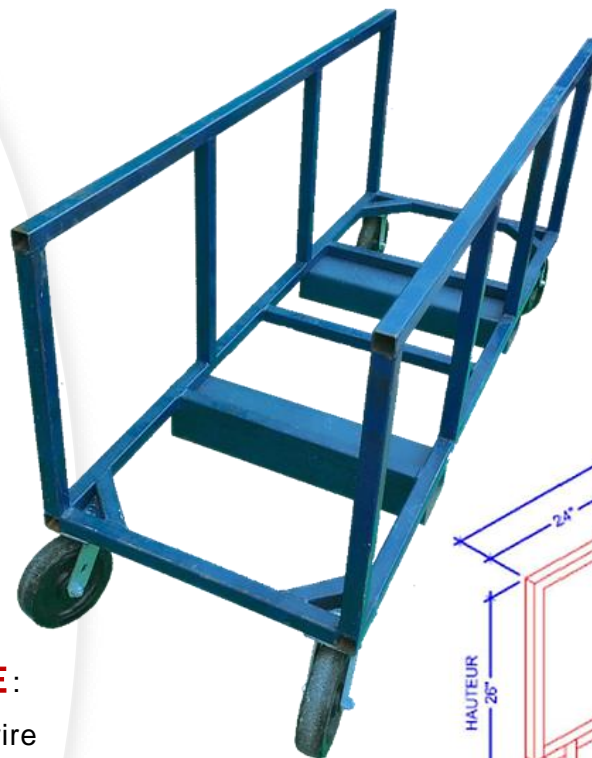

**For information : Francis Leblanc**  
**450 641-1818 x 260**  
**fleblanc@grouperoyaltech.com**